

END SUPPORT (RIGHT) x2	END SUPPORT (LEFT) x2	HARD PAD (RIGHT) x2	HARD PAD (LEFT) x2	RUBBER INSERT FOR PAD (LEFT) x2	RUBBER INSERT FOR PAD (RIGHT) x2	SNAP-ON COVER x4	SECURITY COVER x4	SCREW x4	HEX NUT x4	RIVETS x12	SECURITY BOLT x4	ASSEMBLY KEY x1	CROSS-BAR ASSEMBLY x2

Please Note: You will require the following tools

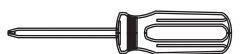

Phillips Head Screwdriver



Rubber Mallet



Safety Knife



Lead Pencil

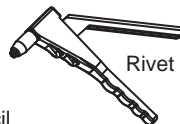

Rivet Gun



Tape Measure



Silicone Adhesive Sealant

ASSEMBLY OF CROSS-BARS

1. Ensure the roof is clean, free from dust and grease.
2. Insert the neck of the End-Support into the void of the Cross-bar profile. They are designed to be a tight fit: use a rubber mallet if necessary (Fig.1)
3. Pull back the rubber Buffer Strip about 20mm until the screw hole can be accessed.(Fig. 2) Using a Phillips Head Screwdriver, fasten the screw through the cross-bar and into the End Support. Do this for all four sides and replace the buffer strip.

NOTE: The longer cross-bars are to be fitted to the front of the vehicle. Check labelling on the underside of the cross-bar.

FITTING CROSS-BARS TO VEHICLE

4. Gently place the Hard Pads onto the vehicle roof relative to the positions shown in Fig.3. Place the pre-assembled front and rear Cross-Bar Assemblies onto the Hard Pads. The End Supports should locate inside the Hard Pads as a snug fit.
5. Using a Tape Measure, measure equal spacing from the edges of the roof channel, to ensure the rack is installed in the middle of the roof. Using a Soft-tip Lead Pencil, mark around all the Hard Pads as well as the 3 rivet holes per Pad. (Fig. 3)
6. Remove the cross-bar assemblies and all other components from the roof. Using a 5mm Diameter Drill-bit, carefully drill out holes in the vehicle roof. A Drill Stop is recommended when drilling to prevent drilling through the interior roof lining. The drill should only penetrate the exterior metal roof body. Carefully remove all metal swarf waste from the roof.
7. Insert the Hex into the bottom side of each Hard Pad. Apply a Silicone Adhesive Sealant (ie, Butyl Mastic/Neutral Cure Silicone) in and around the Hex Nut hole, then insert the Hex Nut into position.
8. Position the Hard Pads back onto the vehicle roof, ensuring the drilled holes in the roof and the mount holes in the Hard Pads are aligned. Use your pencil-marked contour lines to guide you. Locate rivets through the holes and proceed to Pop all the rivets. (refer to Fig. 4 as a guide)
9. Fit the Cross-bar assemblies in place and secure using the Security Bolts. Tighten the bolts until a firm hand tightness is achieved.
10. You are now ready to mount your accessory set onto the cross-bars using the Global Mount Channel. Once installed, insert the 'Global Channel' Covers into the End Supports. You have a choice of 2 - (a) quick access snap-on cover or (b) long term mounting - security cover to cap off and lock the mount channel. (Fig. 4)
11. When Cross-bars are not required on the vehicle, remove the crossbars and insert the Rubber Inserts to cap off the mount faces. (Fig. 6)

FINAL CHECK

After loading, check bolt tightness before departing, and also check regularly during long journeys.

CAUTION:

When installing this roof rack ensure the rivets do not damage or inhibit the effective use of Curtain Airbags. If you are in any doubt regarding the installation of this roof rack, please consult with your vehicle manufacturer or Rola Dealer.

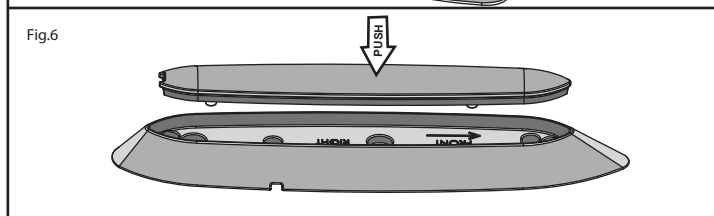
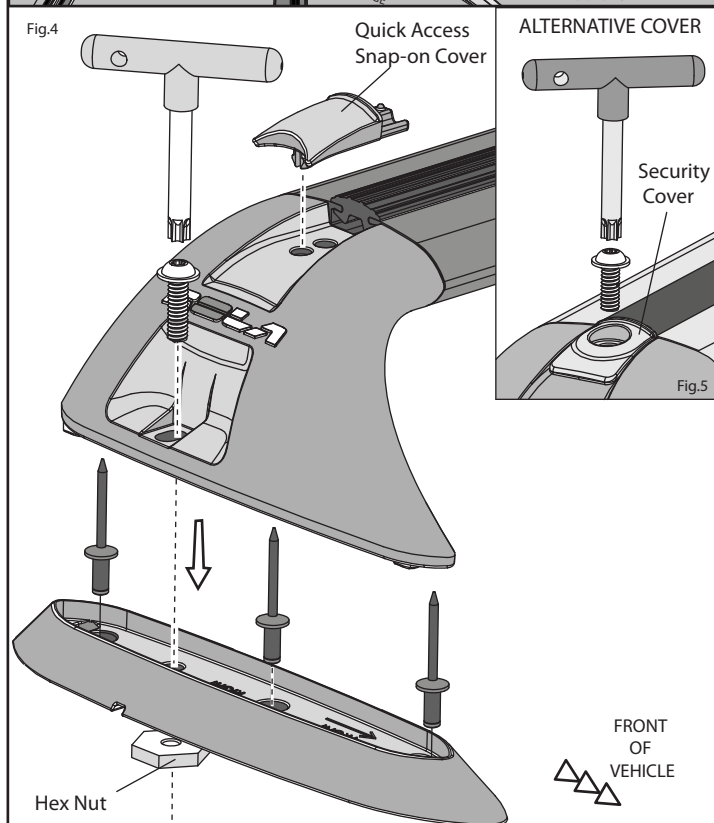
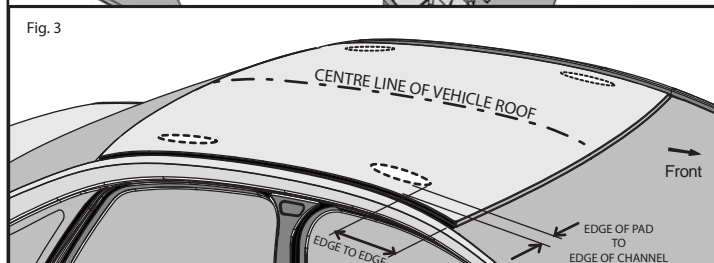
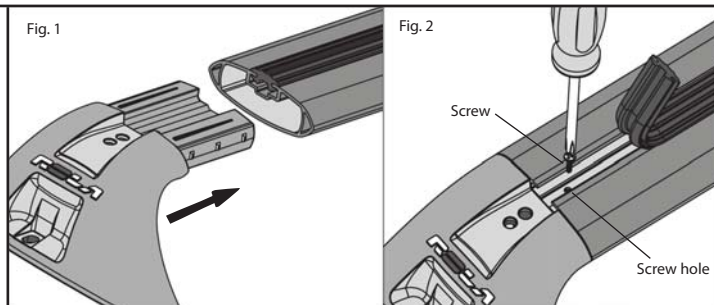

General Usage Information

It is essential for the proper assembly, operation and use of the Roof Rack that the instructions and safety precautions supplied are strictly observed. Read any fitting, care and usage instruction carefully.

The maximum permissible load for your Roof Bar is the lower of the maximum load capacity specified in your vehicle operation manual, or specified as applying to the Roof-Rack. Do not exceed the maximum specified load capacity.

Maximum permissible load = weight of the Roof Rack + weight of accessories + weight of load (cargo).

When fitting the Roof-Rack and transporting a load, ensure the vehicle's functions are not impaired (eg, sunroof, aerials, windscreen wipers, mirrors). Rear doors on Hatch- and Wagon-type vehicles should be inspected for adequate clearance for full opening operation of the boot/tailgate.

Stop and check all screw connections, bolts and retaining straps after a short distance of travel. Repeat these checks at regular intervals.

Warnings

Remember that the fitting of a Roof Rack and the transport of a load increases the overall height of the carrying vehicle.

Where the Roof-Rack is to be used in off-road conditions, a safety weight reduction of 1.5 should be observed from the total carrying capacity. (eg. 60kg becomes 40kg)

Cequent will not be liable to the purchaser or any other person for any consequential, incidental, direct or indirect loss, damage or costs incurred or suffered by the purchaser or any other person including but not limited to damage to persons or property, loss of turnover, loss of profits, loss of business or goodwill, arising from or in relation to the assembly and use of the Roof rack, or the non-observance of the fitting and care instructions.

APPENDICES & ADDITIONAL 'FITMENT SPECIFIC' FITTING STEPS - IF REQUIRED

This area has been intentionally left blank.