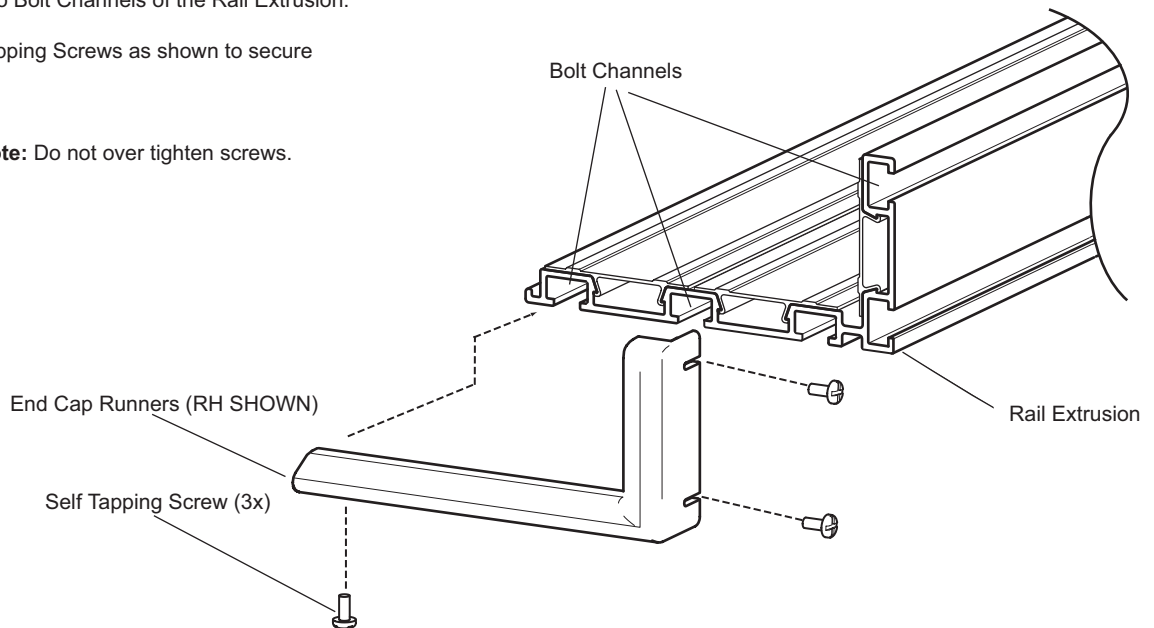
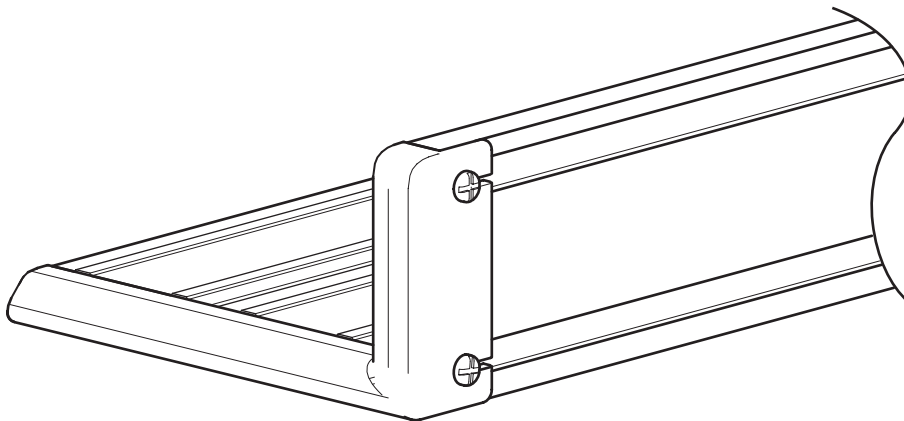

**STEP 1: Assembling End Cap Runner into Rail Extrusion.**

A. Fit End Cap Runner into Bolt Channels of the Rail Extrusion.

B. Fit the supplied Self Tapping Screws as shown to secure the End Cap Runners.

**Please Note:** Do not over tighten screws.

**STEP 2: Assembled End Cap Runner ( Right Hand Shown ).****STEP 3: Removing End Cap Runners.**

A. To remove End Cap Runners reverse the above procedure.